



SELKIRK
TWIN-WALL
CHIMNEY

(125mm to 200mm dia.)

INSTALLATION INSTRUCTIONS & MAINTENANCE GUIDE

United Kingdom

FACTORY- BUILT INSULATED CHIMNEY

**Tested for
compliance with
BS EN1856-1:2003**

**Product Designation
T450 - N1 - D - Vm-L50045 G(50)**

**A MAJOR CAUSE OF CHIMNEY
RELATED FIRES IS FAILURE TO
MAINTAIN REQUIRED CLEARANCES
(AIR SPACES) TO COMBUSTIBLE
MATERIALS**

**IT IS OF THE UTMOST IMPORTANCE
THAT THIS CHIMNEY IS INSTALLED
ONLY IN ACCORDANCE WITH
THESE INSTRUCTIONS**



PLEASE READ ALL INSTRUCTIONS BEFORE BEGINNING YOUR INSTALLATION. FAILURE TO INSTALL THIS SYSTEM IN ACCORDANCE WITH THESE INSTRUCTIONS WILL VOID THE CONDITIONS OF CERTIFICATION AND THE MANUFACTURERS WARRANTY. KEEP THESE INSTRUCTIONS IN A SAFE PLACE FOR FUTURE REFERENCE

MANUFACTURED BY:

SELKIRK CANADA CORPORATION
P.O. Box 526, Depot 1,
Hamilton, Ontario, Canada
L8L 7X6
Tel: 1-905-662-6600
Fax: 1-905-662-5352
www.selkirkcanada.com



DISTRIBUTED BY:

DEKS DISTRIBUTION
Unit 14, Garanor Way
Gordano 19 Industrial Est Portbury, BS20 7XE
Tel: 00 44 1275 373300
Fax: 00 44 1275 373399
Email: sales@deks.org.uk
www.selkirkchimney.co.uk

TABLE OF CONTENTS

PRODUCT IDENTIFIER.....	3
FUELS AND APPLIANCES.....	3
CHOOSING YOUR HEATING APPLIANCE.....	3
GENERAL INSTALLATION RULES.....	3, 4
TOOLS.....	4
FRAMING DETAILS.....	4
CEILING SUPPORT TYPES.....	4 - 6
FIRESTOP TYPES.....	5- 7
ATTIC INSULATION SHIELD.....	8
ELBOW INSTALLATION.....	8, 9
ADJUSTABLE CHIMNEY LENGTH.....	9
135° INSULATED TEE.....	9
ADJUSTABLE WALL SUPPORT.....	10, 11
ADJUSTABLE INTERMEDIATE WALL SUPPORT.....	11
WALL BAND.....	11
ROOF SUPPORT.....	11, 12
ROOF FLASHING.....	12
ROOF BRACE KIT.....	12
CHIMNEY HEIGHT & SIZE.....	13
MAINTENANCE AND CHIMNEY CLEANING.....	14
OFFSET CHART.....	15
WARRANTY.....	16
PRODUCT REGISTRATION / RECORD.....	17

**WHEN INSTALLING YOUR CHIMNEY
REMEMBER...SAFETY FIRST**

If you have a basic knowledge of carpentry, know how to use hand tools and mechanically inclined you can take on the task of installing your new venting system. However it is important that you also review the rules of safety on the following pages and that current building regulations are followed carefully. If you have any doubt concerning your ability to complete or the knowledge of the appliance being connected to your chimney system, you should arrange for a professional installation by a chimney specialist. They will have knowledge and experience to perform your installation in a professional and timely manner and in ensuring that the installation will comply to current building regulations.

IDENTIFIERS OF MODEL PART NAMES AND NUMBERS

The complete part number is prefixed with the ID size, in inches, followed by three (3) letters identifying the system to which it belongs, followed by the actual part identifier (see Figure 1).

NOTE: Use only Selkirk Twin-Wall Chimney components and accessories. Do not use pipe by itself or attempt to fabricate your own support or accessories.

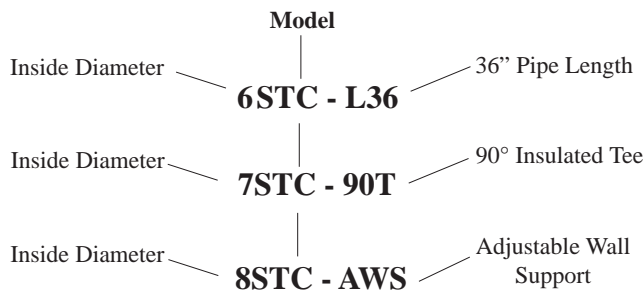

Figure 1 - Example of Product Identifier

FUELS AND APPLIANCES

Selkirk Twin-Wall Chimney conforms to BS EN1856-1:2003 requirements and may be used for venting gas, liquid, or solid fuel fired residential type appliances and building heating appliances in which the maximum continuous flue gas temperatures do not exceed 540°C. It has been tested and approved to withstand temperatures of up to 1000°C for thirty minutes. Chimneys installed in accordance with these instructions will comply with British Standards. Selkirk Twin Wall Chimney is designed for gravity venting only. It is usable on any appliance having a pressure jet burner that operates with neutral or negative draught at the outlet.

CHOOSING YOUR HEATING APPLIANCE

There are three important rules for selecting a woodburning stove, fireplace or heater.

FIRST: Look for a label or nameplate attached to the appliance which bears the mark of name of a recognized testing authority.

SECOND: Do not buy a solid fuel heating appliance which is bigger than necessary.

THIRD: Look or ask for complete installation, operating and maintenance instructions for the appliance. If you can't get these, buy one that gives you all these very important details.

⚠ WARNING

Failure to follow the installation instructions could cause FIRE, CARBON MONOXIDE POISONING, OR DEATH. If you are unsure of installation requirements, call the Telephone Number listed in these instructions.

RULES FOR SAFETY DURING INSTALLATION

1. Read all installation instructions packaged with all support assemblies. If not present, ask your dealer for them. Keep the instructions handy and save them for future reference.
2. Check your local building regulations for all requirements affecting the fuel-burning appliance and its chimney.
3. Be very careful around electrical wiring and be sure it is secured at least 50mm away from any part of the chimney. If wiring must be relocated, hire a professional electrician.
4. Be sure ladders are in good condition and always rest on a level firm surface.
5. Be sure that electrically powered tools are properly grounded.

WEAR CUT RESISTANT SAFETY GLOVES WHEN HANDLING SHEET METAL PARTS WITH SHARP EDGES

Each solid fuel appliance should have its own chimney.

The flue diameter of gas or oil fired appliances should comply with the appropriate installation codes.

Do not place any type of insulating materials or run any electrical wiring within the required clearance air space surrounding the chimney

Locking Bands must be fitted to prevent accidental disengagement during chimney cleaning, and to reinforce the chimney when installed within the building or outdoors, along walls, or above the roof.

The internal diameter of Selkirk Twin-Wall Chimney must conform to the requirements of the heating appliance manufacturer's instructions and should not, under any circumstances, be less than the diameter of the appliance outlet.

When protecting walls or ceilings from the heat of a connector, be sure to leave a ventilated air space between the protection material and combustible construction.

GENERAL INSTALLATION RULES

The combination of lengths used must be such that no joint occurs within the thickness of any floor or ceiling construction, and where connected to flue pipe serving a solid, multi-fuel or oil-fired appliance, the chimney must project at least 150mm below the ceiling before the connection to the flue pipe is made.

Where installed within buildings, Selkirk Twin-Wall Chimney may be fully enclosed at 50mm minimum AIR SPACE clearance to combustibles, including framing timber, drywall, plaster, plywood and other building materials classed as combustible.

For support framing, see Table 1 on page 4 of these instructions.

The Selkirk Twin-Wall Chimney requires 50mm clearance to combustible material or as established by support assembly

All lengths and fittings are designed to be installed with the male coupling uppermost. Joints are achieved simply by placing the female coupling over the male coupling and making a one-eighth turn.

A Locking Band must be used to secure every joint and to ensure a firm connection and to prevent accidental disengagement during chimney inspection and cleaning, and to reinforce the chimney whenever it is outdoors, on walls, or above the roof.

Plan the installation of your chimney in such a way that you locate your chimney and your flue pipe to obtain the shortest and straightest possible connector to the heating appliance. By having too long and / or multiple bend installations you can reduce system draught which can affect the

operation, and /or performance of your appliance and /or chimney system.

The chimney should be located within the building so as to avoid cutting or altering load bearing members such as joists, rafters, studs, etc. If you require to cut or alter an existing load bearing member, special reframing methods apply which often include doubling of adjacent members. If such a case arises, contact your building control official regarding local regulations and proper installation methods.

Where serving SOLID FUEL or OIL appliances, any part of the chimney which passes through any room other than that in which the appliance using the chimney is situated, should be protected to prevent both damage and the accidental location of combustible materials against the outer skin. It is a Building Regulation requirement that ANY factory made insulated chimney should be enclosed where passing through a cupboard, storage space or accessible roof space and applied in such a way that it can be considered as providing access to the chimney.

All chimney enclosures must maintain the required minimum air space clearance of 50mm to the outer wall of the chimney. The enclosures may be fabricated using standard building materials, typically used in this situation is plaster board or plywood mounted on framing members. While properly installed firestops or supports help maintain the necessary clearance to inside surfaces of walls or enclosures; the builder and the chimney installer should take all necessary precautions to assure that this 50mm minimum clearance or more is maintained.

The ideal location for your chimney system is within the building envelope. In cold climates, the use of external chimney may result in operational problems such as poor draught, excessive condensation of combustion products and rapid accumulation of creosote. Under these circumstances, the installation of the chimney within the building is strongly recommended.

If the chimney system must be installed on an exterior wall provide an access door by the Tee Plug for chimney inspection and cleaning.

CONTACT LOCAL BUILDING CONTROL OFFICIAL ABOUT RESTRICTIONS AND INSTALLATION INSPECTION IN YOUR AREA

Before commencing the installation ensure that you obtain any necessary building permits, and that your installation will conform with all Building Regulations requirement.

CHIMNEY JOINTING: Locking Bands must be used on all Selkirk Twin-Wall Chimney joints.

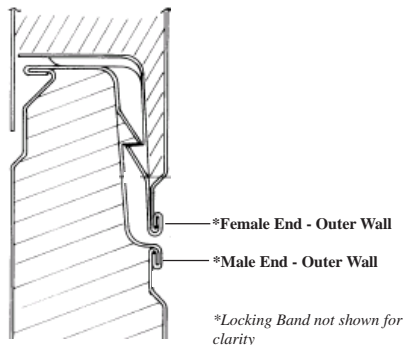

Figure 2

(Close up, Cross-section of Chimney Joint)

WARNING: The chimney pipe and its fittings must be assembled with metal-to-metal joints as furnished. **Do not** use tape or any sealing compound (such as tar, mastic, putty or silicone) at the outer joints. Sealers in the joints may cause the insulation to accumulate moisture and will cause corrosion or freezing failures.

Both the inner and outer pipe must join properly to avoid leakage and accidental disengagement. Slight eccentricity of the inner pipe will not affect operation provided that the joint goes together completely. Minor dents or irregularity of the outer pipe will not have any perceptible effect on temperature safety.

TOOLS

Selkirk Twin-Wall Chimney System is designed for installation using standard building materials and procedures. The following tools / equipment may be required as well as some others depending on the location and structure in which the chimney is to be installed.

- Safety gloves
- Safety goggles
- Hammer and nails
- Tin snips
- Tape measure
- Screwdriver and pliers
- Plumb line and level
- Square
- Keyhole saw or power jig saw
- Caulking gun
- Non hardening waterproof silicone

FRAMING DETAILS

Plan your installation carefully. If possible, position the appliance so that the flue outlet is centered between joists, rafters or studs. Drop a plumb line to the center of the flue outlet and mark this center point on the ceiling. Lay out and frame all openings ensuring the specified 50mm clearance to combustibles is maintained.

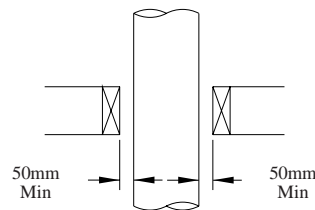

Figure 3
Typical Joist Framing

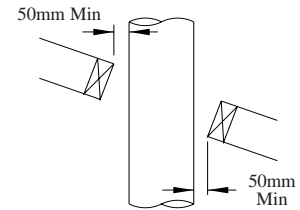

Figure 4
Typical Roof Joist Framing

All openings should be square, plumb and in perfect alignment with each other (see Figure 4). For angled roofs, ensure that the framing dimensions are measured on the horizontal plane (see Figure 4).

TABLE 1 FRAMED OPENING REQUIRED IN FLOOR AND CEILING AREAS FOR FIRESTOP JOIST SHIELDS AND CEILING SUPPORT ASSEMBLIES				
Chimney Size: Inside Diameter	Selkirk Twin-Wall Chimney			
	125mm	150mm	175mm	200mm
Chimney Size: Outside Diameter	179mm	203mm	229mm	254mm
Framing*	279 x 279	305 x 305	330x 330	356 x 356

*To accommodate locating spacers which provide 50mm air gap clearance from chimney outer wall. Check support dimensions before using.

INSTALLATION PROCEDURES

CEILING SUPPORT TYPES (See Pages 6, 7 and 9)

The weight of SelkirkTwin-Wall Chimney may be carried by a number of components according to whether the chimney is installed internally or externally, and whether it is supported by the ceiling, floor or external wall. However, where the Selkirk Twin-Wall Chimney passes through a combustible floor or ceiling and serves a solid or multi-fuel appliance, a Firestop Joist Shield or Telescopic Ceiling Support **MUST** be used to maintain the 50mm clearance and act as a firestop. All Ceiling Support assemblies are intended for installation where the weight of Selkirk Twin-Wall Chimney is taken at the first ceiling penetration above an appliance. The bottom part of all Ceiling Support assemblies fits up against the ceiling side, or a joist opening framed level on all four sides. It is adaptable to all types of chimney-connected appliances, including free

standing fireplaces, solid fuel room heaters, furnaces, stoves and both gas and oil-burning equipment. A chimney length must project a minimum of 150mm below the ceiling level before flue pipe connection is made. Table 2 gives the load bearing capacity of available supports.

Internal Diameter mm	Ceiling Support (STC-CS)	Ventilated Ceiling Support (STC-VCS)	Roof Support (STC-RS)
125mm	15m	15m	9m
150mm	15m	15m	9m
175mm	15m	15m	9m
200mm	15m	15m	9m

1. Ensure the heavier gauge load bearing support plate is installed from above, level and flush to the floor and secure in place with appropriate fasteners into each of the pre-punched holes. Secure the bottom plate of the support in the same manner.

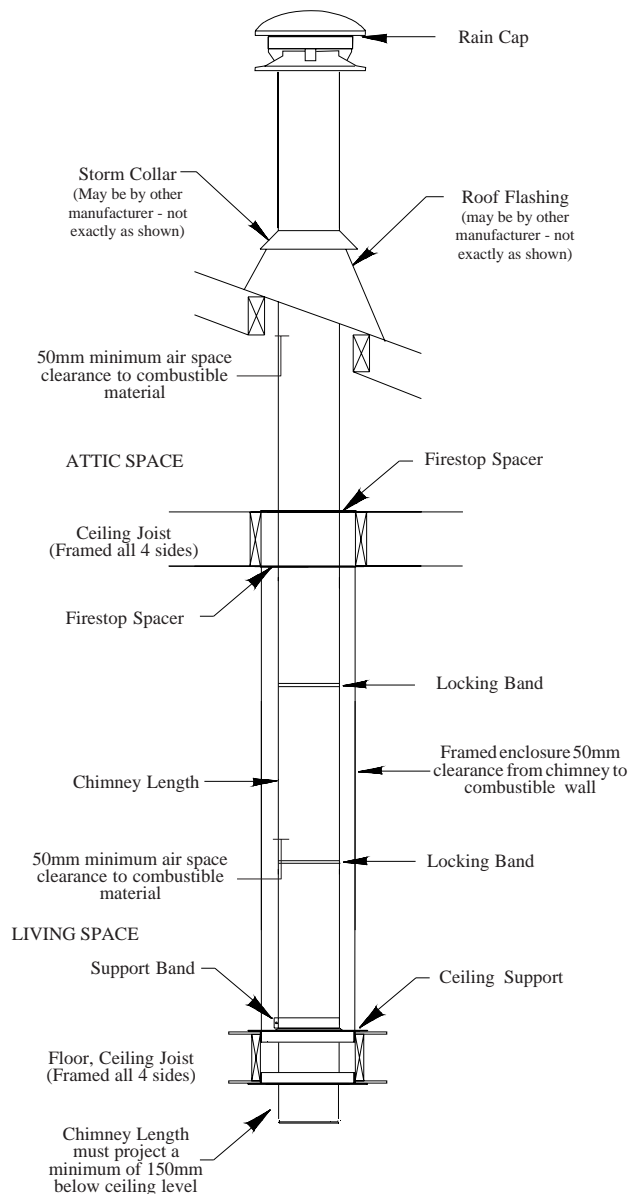

Figure 5- Main Floor of a 2 Level - Dwelling

2. Position the Support Band onto length at the required location and secure in place by tightening the nut and bolt and fastening with the supplied screws. Lower this section through the support assembly.

3. Ensure that the chimney length projects a minimum of 150mm below ceiling level before flue pipe connection is made.

4. Additional chimney lengths above the support are simply stacked on, twist locked with a one-eighth turn and secured with a locking band at each chimney joint. Finish the chimney to its required height.

5. 15°, 30° and 45° Insulated Elbows are available for use where it is not possible to construct a vertical chimney. It should be noted that The Building Regulations require that no part of a chimney used with a solid fuel, wood or oil burning appliance should form an angle of more than 45° from the vertical except where necessary to connect the chimney to the appliance. If an offset is installed in the system, a Wall Band must be installed as shown in Figure 7.

6. If the chimney extends 1.5m or more above the roof, additional lateral support is required, such as the Universal Roof Brace Kit.

WARNING: The chimney lengths and its fittings must be assembled with metal-to-metal joints as furnished. Do not tape or any sealing compound (such as tar, mastic, putty or silicone) at the outer joints. Sealers in the joints may cause the insulation to accumulate moisture and may cause corrosion or freezing failures.

FIRESTOP TYPES

The Firestop is installed into a framed opening (see Framing Details section) from above and below the joist. Secure the Firestop in place with appropriate fasteners.

The following 2pages shows detailed instructions on how to install firestopping and or support components.

Floor penetration and chimney enclosure requirements for the Selkirk STC Chimney System assessed to BS EN 1856-1 at T450.

Building Regulations as well as the approval procedure to which all prefabricated system chimneys are required to be certificated, dictate that an adequate air gap clearance **MUST** be maintained between the outside skin of the chimney and any combustible material. Clearances become more crucial if the chimney is enclosed. The increase in temperature within any enclosure must be dissipated for safety reasons. The approval process for the Selkirk STC Chimney system requires the air gap distance to be not less than 50mm. Where the chimney passes through a room or cupboard and is enclosed, four ventilation grilles **MUST** be used as shown in fig.1 on page 7.

Appropriate components to be used and how they are applied are described in these illustrations and related text and must be followed to ensure that the STC system is applied in accordance with its certificated approval.

These illustrations represent typical configurations over a freestanding solid fuel or wood burning appliance. **NOTE.** If the STC Chimney System serves an appliance which is located within a false chimney breast, it is good practice to provide an air gap clearance of at least 100mm between any combustible material located within the false chimney breast and the outer surface of the chimney.

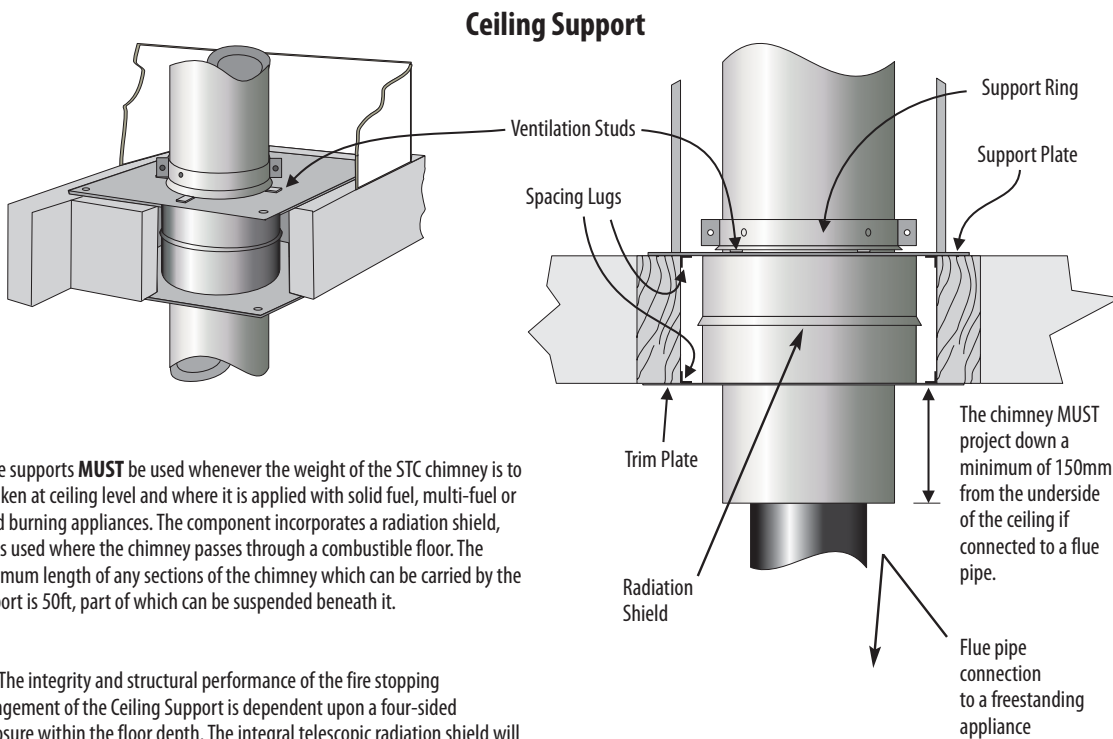

These supports **MUST** be used whenever the weight of the STC chimney is to be taken at ceiling level and where it is applied with solid fuel, multi-fuel or wood burning appliances. The component incorporates a radiation shield, and is used where the chimney passes through a combustible floor. The maximum length of any sections of the chimney which can be carried by the Support is 50ft, part of which can be suspended beneath it.

- 1 The integrity and structural performance of the fire stopping arrangement of the Ceiling Support is dependent upon a four-sided enclosure within the floor depth. The integral telescopic radiation shield will accommodate floor thickness of between 150 and 275mm. Frame a level square opening within the joists using timber stringers where necessary according to the chimney diameter.
- 2 Screw or nail the trim plate to the underside of the frame, so that the lower half of the integral radiation shield is centrally located.
- 3 Locate the Support Plate in position so that the upper half of the radiation shield locates over the lower half of the radiation shield projecting from the lower trim plate. Push down until the two halves of the radiation shield telescope together and the Support Plate rests on top of the frame. Screw or nail into position.
- 4 Lower the chimney through the Support Plate with the support clamping ring loosely positioned.

- 5 Once the known position of the chimney is determined, tighten the clamp support ring to the chimney so that the flares edge rests on the ventilating studs of the Support Plate.
- 6 Using four holes in the clamping support ring as a guide, drill four 3mm holes through the outer wall of the chimney taking care not to pierce the inner skin of the chimney. Using the self-tapping screws provided secure the clamping ring to the chimney wall.

NOTE. The illustrations in this section are Copyright protected and are representative of support components. They are not drawn to scale, and details may vary from those illustrated where design improvements are made.

Firestop Spacers

These non-load bearing supports provide the alternative method for bracing the chimney at the ceiling penetration point into the roof space where the chimney below is enclosed to within 50mm of the outer skin of the chimney surface **AND THE ENCLOSURE IS VENTILATED TOP AND BOTTOM WITH PURPOSE DESIGNED GRILLES**, as shown in fig. 1. They are also used where the chimney penetrates a non-combustible floor.

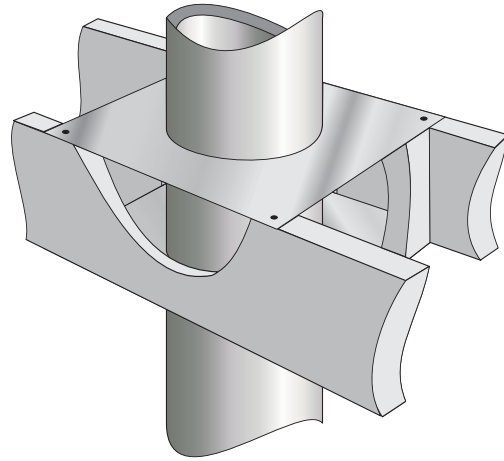
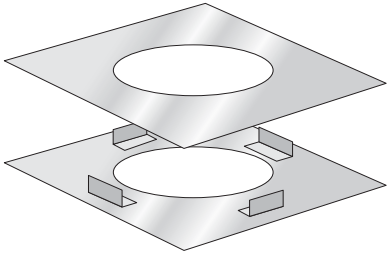

In every case, where grilles are required and used, EACH must have a minimum unrestricted air ingress area of 110cm². They MUST also be used so that the slopes of the inlets point downwards and into the enclosures as shown here.

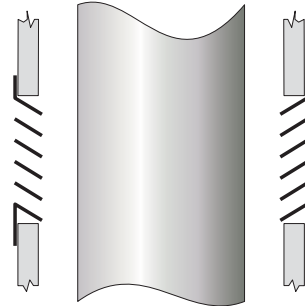

Firestop Spacers used where the chimney beneath is enclosed

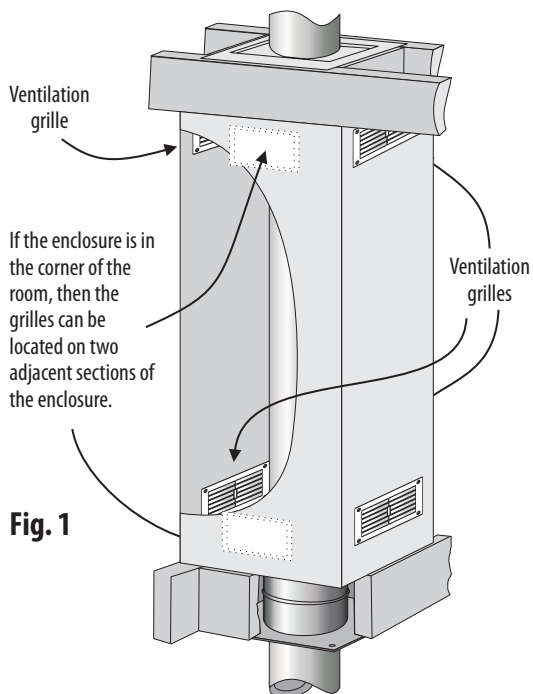

Firestop Spacers used where the chimney beneath is exposed

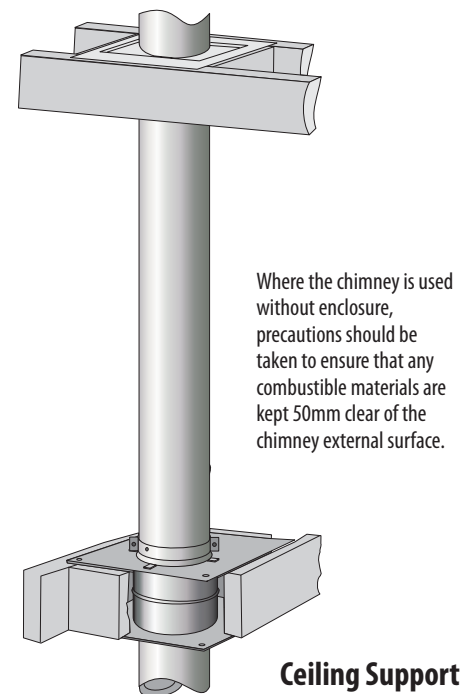

ATTIC INSULATION SHIELD

The function of the Attic Insulation Shield is to keep insulation from coming into contact with the chimney. Where height restrictions will not permit the use of the Attic Insulation Shield, an enclosure from the attic joist to the roof joist will be sufficient. All chimney enclosures must maintain the required minimum air space clearance of 50mm to the chimney.

For proper installation, the attic opening should be fully framed at 50mm clearance (as per Table 3) to the chimney with framing material of the same dimension as the ceiling joists. The tabs on the base plate are to be flattened out and the Attic Insulation Shield centered over the framed opening. Nail the Attic Insulation Shield base to the framing with at least 2 nails per side using 25mm spiral nails or wood screws.

The Attic Insulation Shield allows for a depth of insulation of 254mm plus the depth of the ceiling joists. If insulation is blown in and adheres to the chimney, it should be brushed off to eliminate any possible contact of this material with the chimney surface.

DIAMETER OF CHIMNEY	127mm	152mm	178mm	203mm
FRAMED OPENING	280 X 280	305 X 305	330 X 330	356 X 356
"A" DIM.	184	210	235	260
"B" DIM.	280	305	330	356
"C" DIM.	254	254	254	254
"D" DIM.	330	356	381	406
"E" DIM.	470	470	470	470

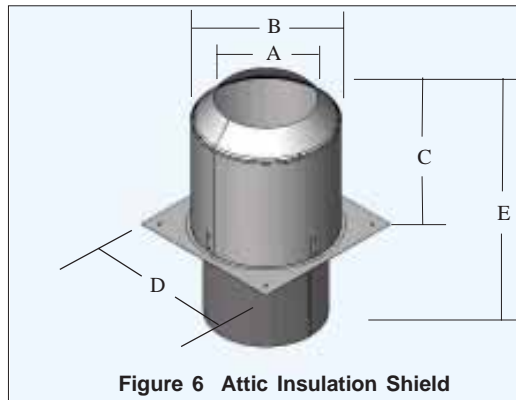

Figure 6 Attic Insulation Shield

ELBOW INSTALLATION

One pair only of two (15°, 30° or 45°) elbows may be used to provide an offset in order to avoid cutting of joists and to clear other obstructions.

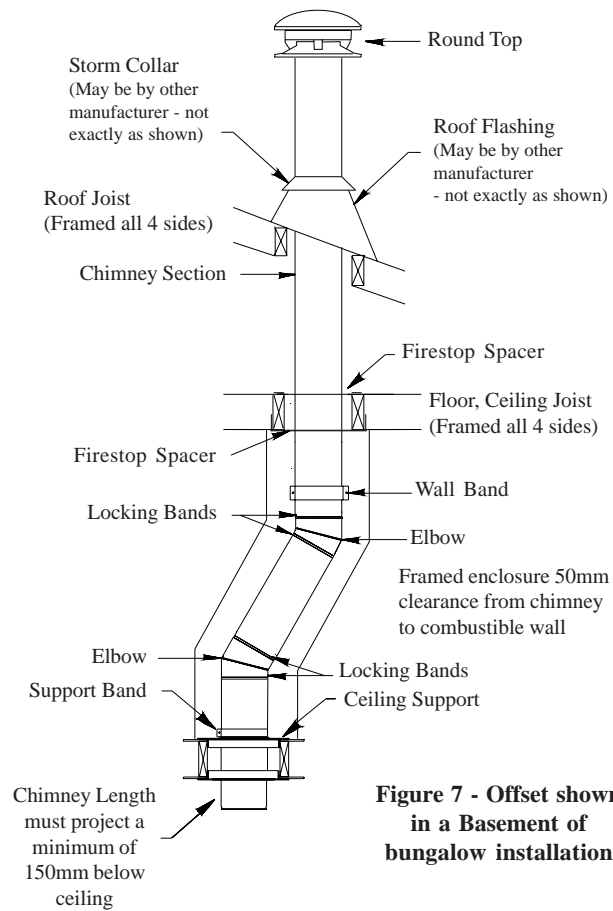

Figure 7 - Offset shown in a Basement of bungalow installation

All offsets should be supported above and below with an appropriate support component i.e. intermediate wall support, ceiling support or roof support.

Flue systems should offer least resistance to the passage of flue gases by minimising changes of direction or horizontal length. A way of meeting the building regulations requirement would be to build flues so that they are straight and vertical except for the connections to combustion appliances with rear outlets where the horizontal section should not exceed 150mm. Where bends are essential they should be angled at no more than 45° to the vertical. Not more than four 45° bends should be used and one 90° Tee used on a rear outlet appliance should be treated as being equal to two 45° bends.

Male and female ends of elbows are not lanced in order to ensure proper alignment of the chimney system can be maintained.

Install and position the insulated elbow on the vertical chimney length in the required direction. Fasten the elbow to the chimney length with the supplied locking band.

Place the required offset chimney length(s) (see Offset Chart for appropriate length(s)) on the elbow.

It is recommended that the maximum offset length should not exceed 20% of the total length of the chimney.

Install the remaining offset elbow to return the chimney back to the vertical position. Again secure in place with the supplied locking band.

During installation provide supplementary support for the offset section to avoid undue stress on connected elbows.

Install a Wall Band on the vertical length just above the highest elbow.

Never install an elbow in a roof/floor joist area. Chimney sections must pass vertically through framed floor or ceiling areas.

ADJUSTABLE CHIMNEY LENGTH

An Adjustable Length is available for chimney installations that require exact lengths. The overall length is 300mm and is adjustable from 50mm to 200mm.

To install, it is simply slipped over the male end of another straight length. Slide the straight length in to achieve the desired net length. Remove some of the packed insulation from the Adjustable Length to

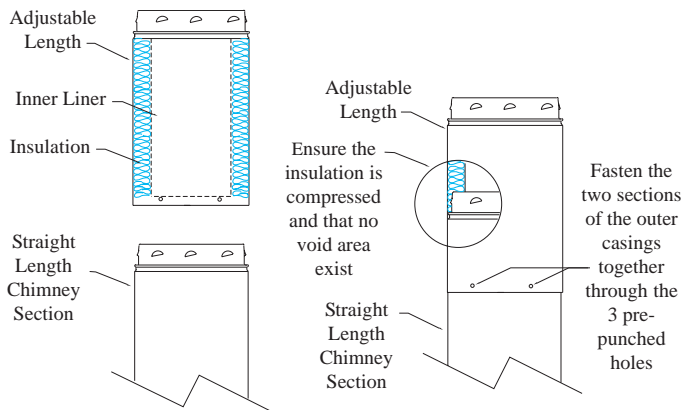

Figure 18- Adjustable Length

allow the insertion of the straight length. It may be necessary to replace some of the insulation so that the insulation is fully compressed and that no void exist.

Fasten the Adjustable Length to the inserted length with stainless steel sheet metal screws through the 3 pre-punched holes (see Figure 8). Do not install the Adjustable Length immediately above a support, elbow or tee.

135° INSULATED TEE

The 135° Insulated Tee is used at the base of a vertical flue. Each Tee is supplied with one Locking Band and Plug. Can be used on the base or branch to provide access.

See Table 4A and diagrams for dimensions of the 135° Insulated Tee and a 45° Elbow positioned in a vertical or horizontal direction.

Table 4B provides dimensions of the 135° Tee with an attached Length with a 45° Elbow also positioned in a vertical or horizontal direction.

	125mm ID Chimney	150mm ID Chimney	175mm ID Chimney	200mm ID Chimney
A	368	394	432	457
B	419	445	483	533
C	267	292	318	343
D	453	457	533	565
E	502	546	584	635
F	286	298	337	356

All dimensions in mm.

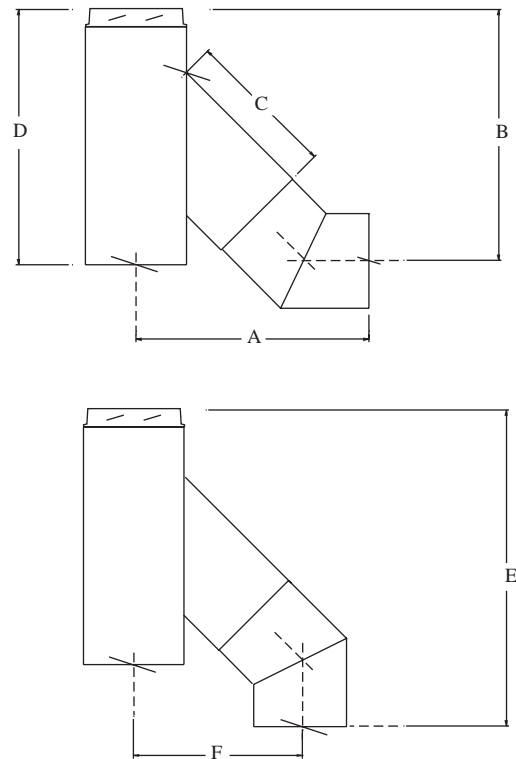

Length	125mm ID Chimney				150mm ID Chimney				175mm ID Chimney				200mm ID Chimney			
	A	B	E	F	A	B	E	F	A	B	E	F	A	B	E	F
150	410	521	610	381	483	610	622	381	553	546	667	420	546	610	711	432
300	559	622	686	470	564	635	737	482	661	648	775	547	654	724	826	546
450	673	723	806	584	698	749	838	597	743	787	889	641	762	838	940	660
600	781	813	905	702	812	851	952	698	858	965	876	775	870	953	1041	781
900	997	1016	1099	908	1022	1067	1168	914	1232	1080	1105	953	1080	1156	1270	965
1200	1219	1149	1334	1130	1219	1270	1130	1359	1270	1334	1422	1182	1295	1359	1473	1181

All dimensions in mm.

ADJUSTABLE WALL SUPPORT

As previously mentioned, the ideal location for your chimney system is within the building envelope. An Adjustable Wall Support is required when the above mentioned location is not possible.

The Adjustable Wall Support will allow for an adjustment of 50.8mm to 152.4mm from a vertical wall. Threaded studs are factory installed on both side brackets and the support plate for fast and easy assembly (see Figure 10 & 11).

See Table 4A for Dimensions of the 135° Tee with 45° Elbow and Table 4B for Dimensions of Length between the 135° Tee and the 45° Elbow.

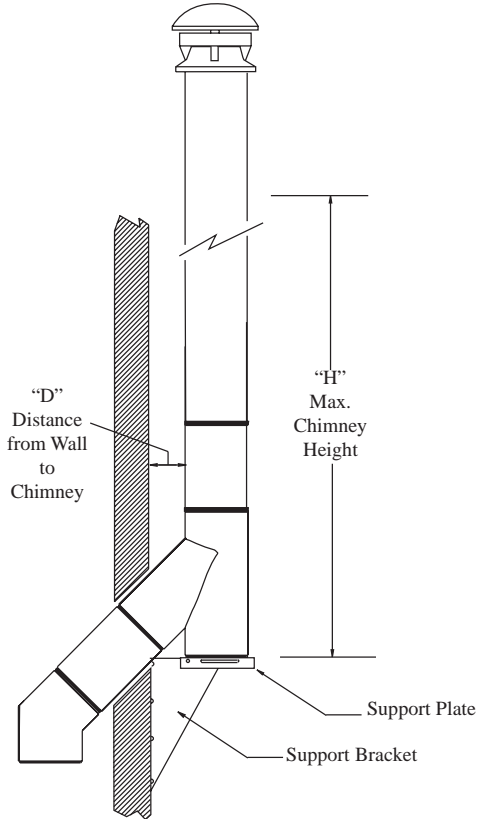

FIG. 9 - See Table 5 for Maximum Chimney Heights based on Chimney Diameter and Distance from Wall

Chart 1 on page 17 will provide Offset Dimensions for 15°, 30° and 45° Elbows.

The maximum chimney height above the Adjustable Wall Support is indicated in Table 5 and illustrated in Figure 9, all of which must be above the support.

The following steps will assist you in the installation of the Adjustable Wall Support. Figure 9 shows a typical installation.

1. Determine the required Length for through the wall application. See Dimension Tables 4A and 4B for dimensions.
2. For a non-combustible wall (concrete block or poured foundation), cut a hole 5mm greater in diameter than the outside diameter of the chimney as per Table 4A Dimensions for 135° Tee and Extensions.
3. Assemble the side Brackets (point of triangle facing down) to the Support Plate (flange up) by inserting the threaded studs into the oblong slots. Install the supplied nuts on the threaded studs (see Figures 10 & 11).
4. Ensure that the Adjustable Wall Support is level and that once installed the Tee lines up with the hole opening. Secure to the wall through the

pre-punched holes located on the sides of each of the wall support brackets using (8) #14 x 38mm hex head lag screws or #10 x 38mm wood screws.

"D" (mm) Distance from Wall to Chimney (mm)	Table 5 - Wall Support Chimney Height Chart			
	125mm ID Chimney	150mm ID Chimney	175mm ID Chimney	200mm ID Chimney
	H (m) Max. Height	H (m) Max. Height	H (m) Max. Height	H (m) Max. Height
50.8	22.6	19.2	17.1	14.9
63.5	22.3	18.9	16.8	14.6
76.2	21.6	18.3	16.1	14.3
88.9	21	18	15.5	14
101.6	20.1	17.1	14.9	13.4
114.3	18.9	16.1	14	12.8
127	17.7	15.2	13.1	11.9
139.7	15.8	13.7	11.6	10.7
152.4	13.7	11.9	10.4	9.1

NOTE: This Table is applicable only for chimney diameters of 125mm to 200mm

5. Once in its final position and all clearances have been met, tighten each of the nuts on the threaded studs.

6. Attach the two (2) retainer clips to the bottom of the support plate and fasten with the supplied nuts and bolts using the two (2) holes on top of the support plate (see Figures 10 & 11).

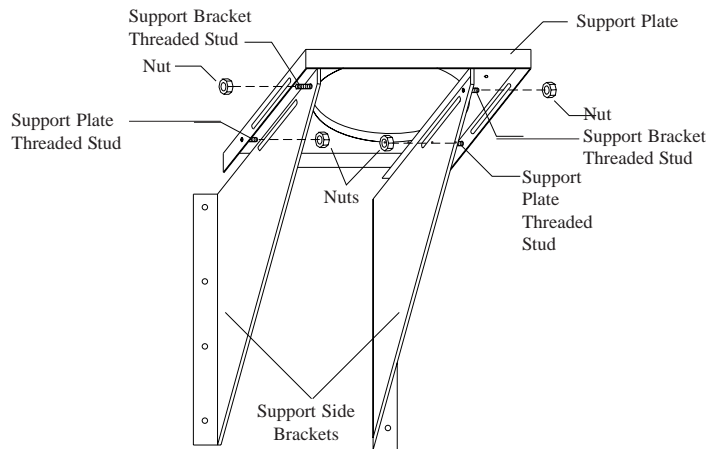

Figure 10- Underside view of location of threaded studs and nuts

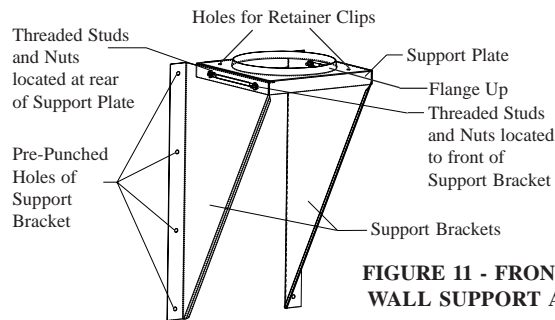

FIGURE 11 - FRONT VIEW OF WALL SUPPORT ASSEMBLY

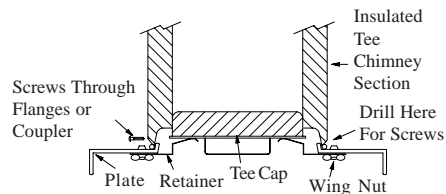

Figure 11A

WARNING: Tee Cap and Retainers must be installed. Failure to install retaining clips could cause fire, injury or death.

9. Place the Insulated Tee on the support plate ensuring that the male coupler of the Tee is facing up and the flange on the top of the plateslides into the female coupler. Insert and secure the Tee Cap (see Figure 11A) with the attached retainer clips. A Tee Plug with drain is also available for condensation and provides access for cleaning out soot/and debris.

10. For lateral stability of the chimney above the support, a Wall Band must be used every 2.5 meters, and at least one Wall Band must be installed. Interior chimneys must use the Firestop Joist Shield in place of Wall Bands if extending through floor/ceiling penetrations.

NOTE: Inverting the brackets (brackets mounted above the support plate) can be accomplished by inserting extra bolts through the oblong slots of the support side brackets and the support plate as per Figures 12 and 13. Secure with nuts. In this position, the range of adjustability is limited to 127mm from the wall.

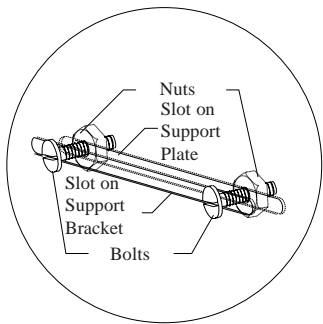
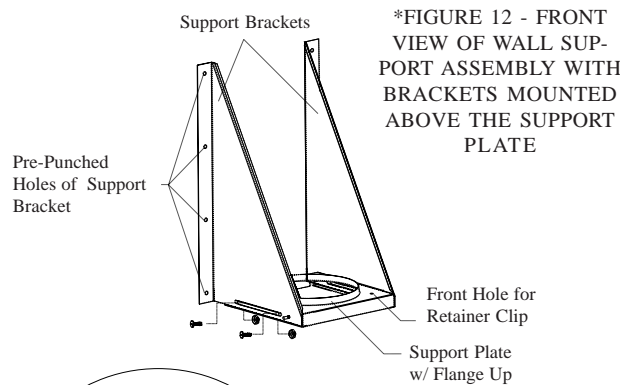

FIGURE 13- SLOT AREAS WITH BOLTS AND NUTS ASSEMBLY OF SUPPORT BRACKET AND SUPPORT PLATE

ADJUSTABLE INTERMEDIATE WALL SUPPORT :

If the total chimney height exceeds the Wall Support limitations, an Adjustable Intermediate Wall Support must be installed. Use of an AIWS will support another 9 meters of chimney.

Slide the assembled intermediate wall support over the protruding length of chimney. Fasten the AIWS to the wall using four 1/4" by 2" wood screws through the pre-punched slots in each bracket.

Install the draw band around the protruding chimney length securely against the support plate. Install 4 stainless steel sheet metal screws firmly into the outer casing of the chimney, through the pre-punched holes in the draw band.

Cover the heads of the screws with a non-hardening waterproof caulking.

WALL BAND: (SEE Figure 18 Below)

The Wall Band is used along an outside wall at 2.5 meters intervals for stability. Position and secure the Wall Band to the wall with appropriate fasteners. Fasten the band around the chimney with the supplied nuts and bolts. For concrete walls use suitable masonry fasteners.

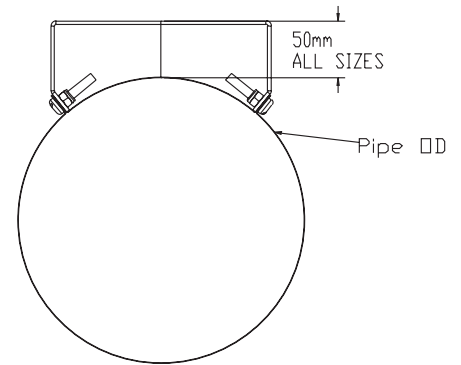
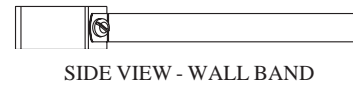

FIGURE 14 - WALL BAND

TOP VIEW - WALL BAND



SIDE VIEW - WALL BAND

ROOF SUPPORT:

The following instructions will assist you in the installation of Selkirk Twin-Wall Chimney with a Roof Support. This support will hold up to 9.0m of chimney of which 6.0 m may be suspended beneath it.

1. Frame a rectangular roof opening to provide a 50mm minimum clearance from combustible materials (See Figure 15).
2. Bend both chimney plates at vertical slots to fit outside curvature of a selected Chimney Length (Figure 15).

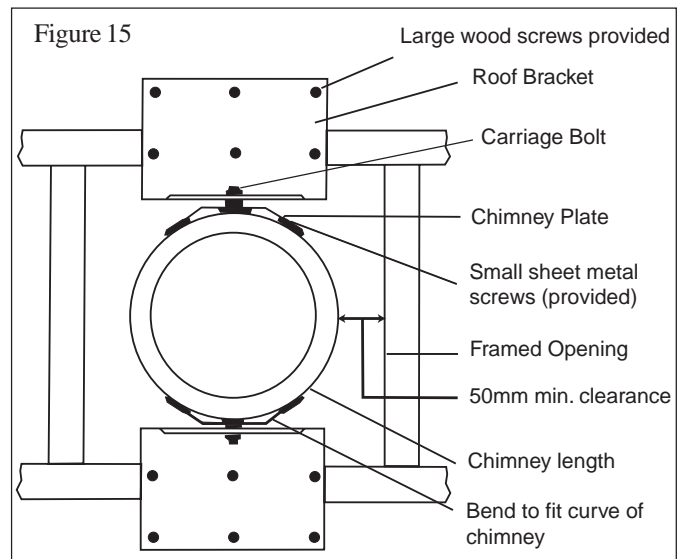

3. Determine the chimney plate position on the chimney casing.
4. Install two (2) carriage bolts per chimney plate in square holes.
5. Using the bent chimney plate as a template, drill a starter hole in the outer casing of the chimney. (Do not penetrate more than 12 mm into the chimney). Attach plate with small sheet metal screws provided.
6. Install second plate in a similar manner on the opposite side of the chimney length.

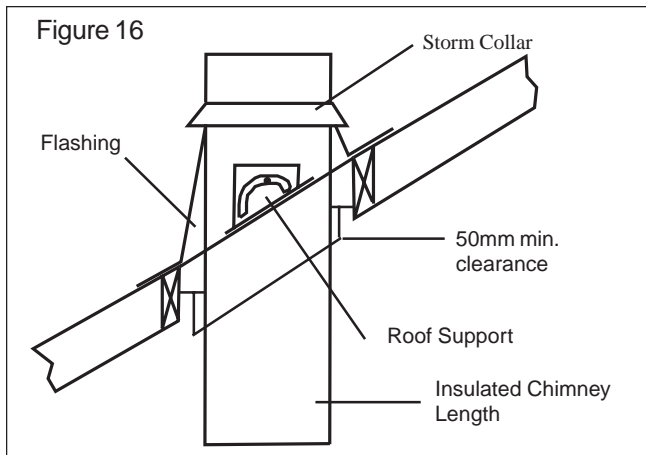

7. Attach Roof Brackets to the chimney plates. Centre the assembly in the roof opening, ensuring that a 50mm clearance to combustibles is maintained.

8. Adjust Roof Brackets to the roof pitch and tighten nuts. Attach to the roof with six (6) large wood screws per bracket with the inner-most screws going into the rafters or headers (See Figures 15 & 16).

9. Additional chimney Lengths above the support are simply stacked on and twist locked with a one-eighth turn.

10. Locking Bands must be used on all joints.

11. Finish the chimney to its required height. If the chimney extends 1.5 m or more above the roof, a Universal Roof Brace Kit is required (see Figure 17).

ROOF FLASHING:

Seldek flashings are available to provide the appropriate weather cover where a chimney penetrates the roof. To fit, trim the EPDM cone to suit pipe size using sharp tin snips or scissors. Slide the flashing down over the pipe using water as a lubricant. Dress the base of the flashing over the profile of the tiles or slate. Provided the cone has been cut to the appropriate size the use of sealant or storm collar is not necessary.

Follow the Roof Flashing manufacturer's installation instructions for proper flashing installation.

The chimney may be painted with a HEAT RESISTANT paint. To improve adhesion to the Twin Wall chimney, degrease, clean, prime before painting. Follow the paint manufacturer's instructions.

6. Continue adding chimney lengths until the proper height is achieved (see Figure 1 and Framing TABLE 1 on page 4). Install a Round Top or Rain Cap. Other terminations are also available.

ROOF BRACE KIT:

If the chimney extends 1.5m or more above the roof, a Universal Roof Brace Kit is required. This Kit contains 2 telescopic legs, a draw band, hardware package and is suitable for this application.

Follow the instructions included in the Universal Roof Brace Kit Assembly. Position the band at a point about 2/3's of the overall chimney height above the roof but never lower than 1.5m (see Figure 17). The draw band is clamped around the chimney and

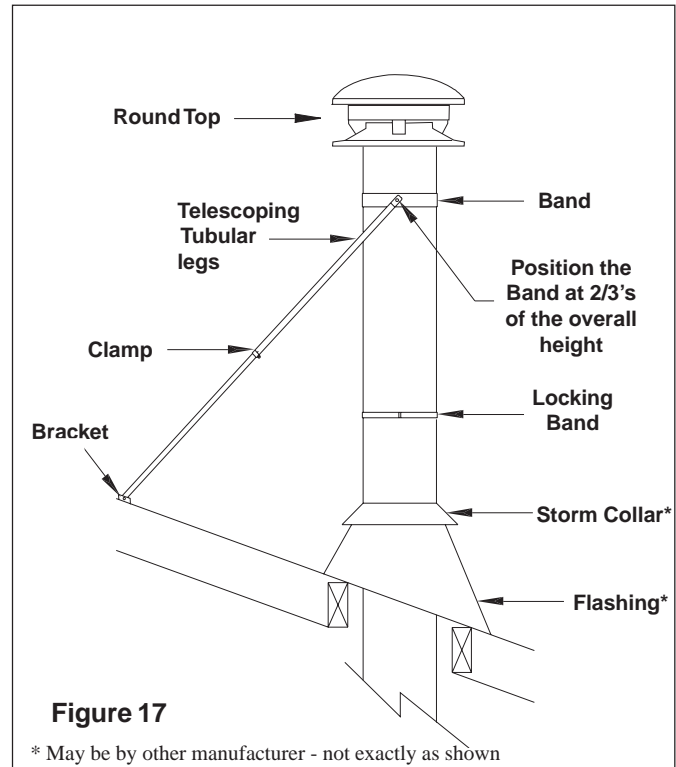

the two legs bolted to the roof. The preferred location for the draw band is next to a joint, immediately above or below a locking band. The two telescopic legs should form an angle of about 60 degrees to give support to the chimney in all directions. Secure bottom end of legs to brackets and brackets to roof with hardware as shown in Figures 17 and 18, keeping bottom ends equal distant from pipe and at approx. same elevation, on high side of sloped roof. Ensure that the lags are secured into the rafter and not just the roof deck.

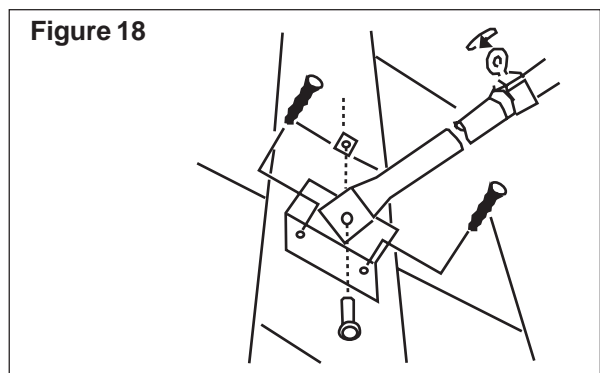

Seal the roof with a suitable waterproof sealant. After the legs are attached to the chimney and band, tighten the clamps on the legs to fix the position of the telescopic legs (see Figures 17 and 18).

CHIMNEY HEIGHT AND SIZE

Before beginning the installation of the chimney be sure that the selected size is adequate for the appliance and the selected height of the Chimney system is high enough to conform to all requirements. See diagrams and Table 6 below.

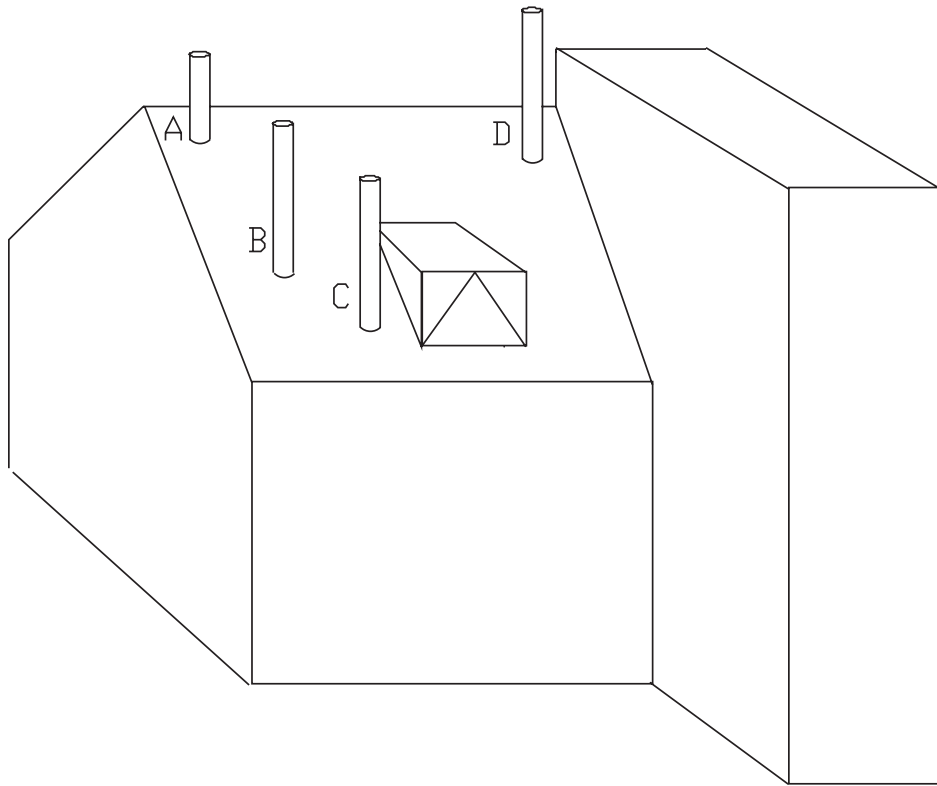

Table 6

Points where flue passes through weather surface (Notes 1, 2)		Clearances to flue outlet
A	at or within 600mm of the ridge.	at least 600mm above the ridge.
B	elsewhere on a roof (whether pitched or flat)	at least 2300mm horizontally from the nearest point on the weather surface and: a) at least 1000mm above the highest point of intersection of the chimney and the weather surface; or b) at least as high as the ridge.
C	below (on a pitched roof) or within 2300mm horizontally to an openable rooflight, dormer window or other opening. (Note 3)	at least 1000mm above the top of the opening.
D	within 2300mm of an adjoining or adjacent building, whether or not beyond the boundary. (Note 3)	at least 600mm above the adjacent building.
<p>Notes</p> <p>1) The weather surface is the building external surface, such as its roof, tiles or external walls.</p> <p>2) A flat roof has a pitch less than 10 degrees.</p> <p>3) The clearances given for A or B, as appropriate, will also apply.</p>		

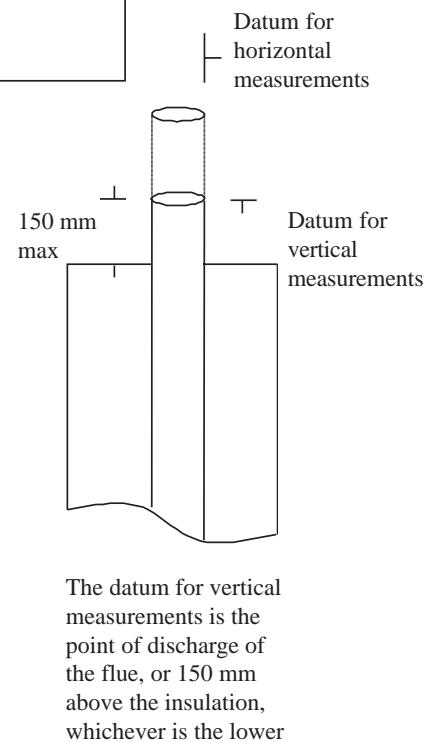

Figure 19 RULES FOR CHIMNEY HEIGHT ABOVE THE ROOF

MAINTENANCE AND CHIMNEY CLEANING:

The need for chimney maintenance depends on the kind of appliance and how it is operated. Gas and oil-burning appliances need very little, but wood and coal-burning appliances may need a great deal of chimney maintenance.

Good operating and firing techniques of your wood burner will have a positive impact in reducing creosote build-up. Burn hot, bright fires and fire each load hot. It is important to load your appliance properly and to avoid smoldering fires. By doing so, it reduces the risk of chimney fires and creosote formation. If your wood is not thoroughly seasoned, split it in smaller pieces instead of larger ones. Ideally, the moisture content of your firewood should be between 18 and 22 percent. A good investment in assisting you in monitoring your system is a surface thermometer for single wall flue pipe or a probe thermometer for double wall flue pipe.

When wood is burned slowly, it produces tar and other organic vapors, which combine with expelled moisture to form creosote. The creosote vapors condense in the relatively cool chimney flue of a slow-burning fire. As a result, creosote residue accumulates on the flue lining. When ignited, this creosote makes an extremely hot fire. Just 1/16" thick is enough to cause a chimney fire.

With a new installation, the chimney should be inspected frequently (every 2 wks) to determine the rate of creosote formation. When familiar with the appliance and chimney characteristics, the chimney should be inspected at least once every 2 months during the heating season to determine if a creosote or soot build-up has occurred. Check spark arrester screens at least every 2 to 4 weeks as creosote accumulation forms more rapidly with their use.

If creosote or soot has accumulated, it must be removed to reduce the risk of chimney fire. Depending on the rate of build-up (as little as 1/16") and as you learn what is going on in the chimney, you can adjust your cleaning schedule accordingly. Every chimney flue and flue pipe shall be inspected annually and cleaned as often as may be necessary to keep the chimney and flue pipe free from dangerous accumulation of combustible deposits.

If you have any doubts about your ability to clean the chimney, or if the deposits are very heavy and hard to remove, contact a local certified chimney sweep for chimney cleaning services. Do not try to burn them off.

Care should be taken when the Rain Cap (or other termination) is removed as not to disengage any lower chimney sections. Removing the Rain Cap will permit the insertion of a properly sized plastic chimney cleaning brush. A metal brush may scratch the liner and lead to premature corrosion. The Tee Plug can be removed by turning the retainer clips. Be sure to replace the Rain Cap and the Tee Plug once you have finished inspecting and cleaning of the chimney.

To reduce corrosion in a chimney where coal is burnt, the chimney should be thoroughly cleaned within 48 hours of shutting down the appliance for the season and all soot be removed from the chimney system. Ensure that only low sulphur content coal (1% or less) such as anthracite is burned. It is of the utmost importance that all soot be removed.

If chemical cleaner is used to assist in the cleaning of your chimney, make sure it is a product which is non corrosive to the chimney liner. The optimal method for cleaning a chimney is by a mechanical brushing of the chimney in conjunction with a complete evaluation of the system by a certified chimney sweep.

WARNING:

DO NOT USE FUEL MATERIALS CORROSIVE TO THE CHIMNEY LINER SUCH AS DRIFTWOOD, PLASTICS, CHEMICALLY TREATED WOOD, ETC.

Creosote causes many problems. Some are visible while others are not. It can make trouble if:

1. It runs down the outside of the pipe to damage the finish on the metal.
2. It drips out of joints, damaging floors or furnishings.
3. It plugs up the chimney to cause poor combustion, smoking, soiling walls and indoor air pollution.
4. It catches fire in the chimney to cause possible chimney damage and damage to your home.

It doesn't matter how careful you are with loading, fuel wood selection or draught control, you should observe the above precautions with any wood stove or chimney installation.

CHIMNEY FIRES AND WHAT TO DO ABOUT THEM:

Selkirk Twin-Wall Chimney is not intended or designed for use as a combustion or fire chamber. It is very easy to overfire your woodburning appliance with kindling, scrap timber, brush or any fast burning fuel. This can produce flames and high temperatures all the way up the chimney, and may cause appliance and chimney damage. The following materials should not be burned in your woodburning appliance: pressure treated timber, railway sleepers, salt water driftwood or plastic. Burning such materials may lead to severe corrosion of the appliance and the chimney system.

If you see your appliance or the flue pipe glowing red, you are risking chimney damage or a fire. The creosote may be burning inside the chimney.

If the fire in your appliance has become out of control, or if you suspect a chimney fire for any reason, follow these steps:

1. Immediately close all dampers and/or air entrance openings to your appliance. Block off fireplace openings.
2. Alert your family to the possible danger.
3. Inspect your appliance and chimney surroundings for possible fire. If in doubt, alert your Fire Brigade.
4. Do not continue to operate your appliance until it and your chimney have been thoroughly inspected. Overheating can cause metal parts to expand, buckle and crack. If you are not certain, have a certified technician or certified chimney sweep disassemble all parts so they can be inspected and replaced.
5. Do not use salt or water on the fire in your appliance. Salt is corrosive and water will cause a dangerous steam explosion. You might be able to control the fire by using ashes, sand or baking soda, since baking soda is an ingredient used for dry chemical fire extinguishers.
6. After a chimney fire, when it is safe to do so, check internal locations such as the attic and under the roof and keep watching for two or three hours. There may be delayed smoldering and subsequent ignition, even if the fire inside the chimney has been controlled.

When the chimney path cannot be perfectly straight, the need to install a chimney offset must be used when it becomes necessary to offset the chimney in order to clear a joist or an obstacle. The 3 charts will assist you in selecting the proper combination of elbow angle and chimney length(s) to provide the necessary degree of offset within an available height.

1. Select the column with the proper chimney diameter of your system.

2. Determine the distance of the offset required by dropping a plumb line for an accurate measurement. The offset is measured at the chimney centre line as per the "A" Offset measurement in the diagram below.

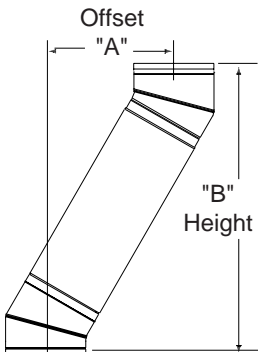

3. On the chart, find the predetermined distance (under the "A" column) required for the 15° elbow. For greater offset, use the 30° offset chart and if permissible, the 45° chart.

4. After finding the offset, look at the "B" (Height) measurement in the diagram above and under column "B" in the chart to find the specified height. The appropriate "Chimney Lengths" required in between elbows is located in the left hand side column on the chart.

15° OFFSET CHART								
Chimney Lengths	125mm Diameter		150mm Diameter		175mm Diameter		200mm Diameter	
	A	B	A	B	A	B	A	B
none	25	210	25	232	25	225	25	219
6"	57	327	57	348	57	342	57	335
12"	95	474	95	496	95	489	95	483
18"	136	621	136	643	136	636	136	630
24"	175	769	175	790	175	784	175	777
12" & 18"	206	885	206	907	206	900	206	894
36"	254	1063	254	1085	254	1078	254	1071
12" & 36"	325	1327	325	1348	325	1342	325	1335
18" & 36"	364	1474	364	1495	364	1489	364	1482
12"&18"&36"	435	1738	435	1759	345	1753	345	1746
48"	333	1357	334	1379	333	1372	333	1366

30° OFFSET CHART								
Chimney Lengths	125mm Diameter		150mm Diameter		175mm Diameter		200mm Diameter	
	A	B	A	B	A	B	A	B
none	90	340	90	394	105	407	164	407
6"	150	444	150	499	164	511	241	524
12"	228	576	228	630	241	643	317	656
18"	303	708	303	762	317	775	395	788
24"	379	840	379	894	395	907	530	920
12" & 24"	517	953	517	1131	530	1144	545	1156
36"	532	1104	532	1158	545	1171	681	1184
12" & 36"	669	1341	669	1395	681	1407	758	1420
18" & 36"	745	1472	745	1527	758	1539	835	1552
24" & 36"	821	1605	821	1659	835	1672	972	1684
12"&24"&36"	958	1841	958	1895	972	1908		1921

45° OFFSET CHART								
Chimney Lengths	125mm Diameter		150mm Diameter		175mm Diameter		200mm Diameter	
	A	B	A	B	A	B	A	B
none	120	304	120	305	140	356	140	384
6"	205	389	205	390	225	441	225	469
12"	313	497	313	498	333	549	333	577
18"	421	605	421	606	441	657	441	685
24"	529	713	529	713	548	765	548	793
12" & 24"	722	906	722	906	742	958	742	986
36"	744	928	744	929	764	980	764	1008
12" & 36"	937	1121	937	1122	958	1173	958	1201
18" & 36"	1045	1229	1045	1230	1065	1281	1065	1309
24" & 36"	1153	1337	1153	1337	1173	1388	1173	1417
48"	955	1144	955	1144	980	1196	980	1224

Deks Distribution is the exclusive distributor of Selkirk products in the UK

LIMITED LIFETIME WARRANTY

Selkirk Chimney & Venting Products

Selkirk Canada Corporation, (“Selkirk”, “we”, “us”, “our”) warrants Selkirk products* to be free from defects in material and workmanship for as long as the original consumer owns the system. For products installed after January 1, 2006, for a period of Ten (10) years from original installation, we will provide replacement product with a similar or like quality of available Selkirk product, **free of charge** excluding any installation costs. From the Eleventh (11) through Fifteenth (15) years we will provide replacement product to the original consumer at a cost of 75% off the published Retail Price in effect on the date the claim is received excluding any installation costs. At expiration of the Fifteen (15) year term, we will provide replacement product to the original consumer at a cost of 50% off the published Retail Price in effect in effect on the date the claim is received excluding any installation costs.

LIMITATIONS:

- Products must be installed for their intended purpose and in accordance with current Selkirk installation instructions.
- Products must be connected to an appliance listed with an accredited testing laboratory.

WARNING: FAILURE TO INSTALL SELKIRK PRODUCTS ACCORDING TO THE MANUFACTURER’S INSTRUCTIONS WILL VOID ALL APPLICABLE WARRANTIES AND MAY RESULT IN FIRE, CARBON MONOXIDE POISONING OR DEATH. SEE OUR SELKIRK INSTALLATION INSTRUCTIONS FOR COMPLETE INSTALLATION PROCEDURES.

WARRANTY COVERAGE:

This warranty covers any substantial defects in material and workmanship in normal use that are found to exist in any of the insulated chimney sections or component parts of your chimney with the exception stated below.

THIS WARRANTY DOES NOT COVER:

- (a) any non-stainless base tee unit mounted or connected to an Insulated Chimney system;
- (b) **costs (labor or otherwise **) associated with either removing a previously installed product, installing a replacement product, transportation or return of a product, or transportation of replacement product;**
- (c) damage to the finish of products caused by the use of improper solvents/chemicals or improper cleaning methods;
- (d) damage resulting from failure to reasonably clean, care for or maintain products in accordance with our installation instructions/recommendations;
- (e) damage (to products, appliances or structure on

- or resulting from improper installation or repair, misuse or abuse (including, but not limited to, excessive or improper operating condition), or alteration or adjustment other than in conformity with our installation instructions and specifications, whether performed by a contractor, service company, technician, or yourself;
- (f) any products that have been moved from their original installation site.
- (g) damage caused by burning driftwood, garbage, or any other prohibitive material which has been burned in the appliance served by the chimney
- (h) damage that results from accidents such as fire, flood, high winds, “acts of God”, or any other contingency beyond our control.

**** Due to the wide variance in installation practices and other conditions beyond our control, we do not guarantee or in any way warrant the installation of Chimney and Venting products. Chemically contaminated combustion air will affect the durability and therefore longevity of both the chimney and the appliance it serves. The chimney system is vulnerable to flue gas by-products, particularly if the chimney is not regularly maintained and cleaned.**

CLAIM PROCEDURE:

If you believe that a product fails to meet the above limited warranty, notify us in writing at the following location:

SELKIRK CANADA CORPORATION
P. O. Box 526, Depot 1,
Hamilton, ON, CANADA, L8L 7X6
ATTN: WARRANTY CLAIMS DEPARTMENT
www.selkirkchimney.co.uk

Notification should include a description of the product, model and part number and how the product fails to meet the above warranty. Upon receipt of a written claim under this limited warranty and evidence of the date of purchase or installation, at our option and in our sole discretion, we will either repair or replace the product with similar or like quality of available Selkirk product per this warranty excluding any installation costs. Selkirk Canada Corporation reserves the right to inspect or investigate any warranty claims prior to determining whether to repair or replace the product. If, as determined by Selkirk Canada Corporation repair or replacement of the product is not commercially practicable or cannot be completed in a timely manner, we may refund the purchase price paid for the product, prorated to the terms of this warranty, upon verification by providing a copy of your invoice or receipt of bill of sale.



INSTALLATION INFORMATION

Keep in a safe place for future reference

CHIMNEY MODEL: _____

TYPE OF APPLIANCE: _____

INSTALLATION DATE: _____

DESCRIPTION OF INSTALLATION (Chimney and Pipe Connector Configuration) _____

PURCHASED FROM:

DEALER NAME: _____

Address: _____

Town/City: _____

Country: _____

INSTALLED BY:

TECHNICIAN NAME: _____

Address: _____

Town/City: _____

Country: _____



PRODUCT REGISTRATION

Please register your Chimney with the Manufacturer.

**Mail to: Selkirk Canada Corporation
Product Registration, P.O. Box 526, Depot 1, Hamilton, ON, Canada L8L 7X6**

Register Online @: www.selkirkchimney.co.uk

Name: _____

Address: _____

Town/City: _____

Country: _____ **Zip Code:** _____

Chimney Model: _____ **Installation Date:** _____

Technician Name: _____ **Address:** _____